

PACK LEADER

PL-622 FRONT & BACK LABELER

Stepper Driven

The PL-622 FRONT & BACK LABELER is suitable for a variety of shapes of products for one side or two sided labeling using a touch screen control system for easy setting, high speed & accurate labeling. The adjustable guide rails allows you to accommodate different shapes of products, and the hand wheels makes it easy to adjust. Castors and threaded leveling feet are installed on the chassis for greater mobility.

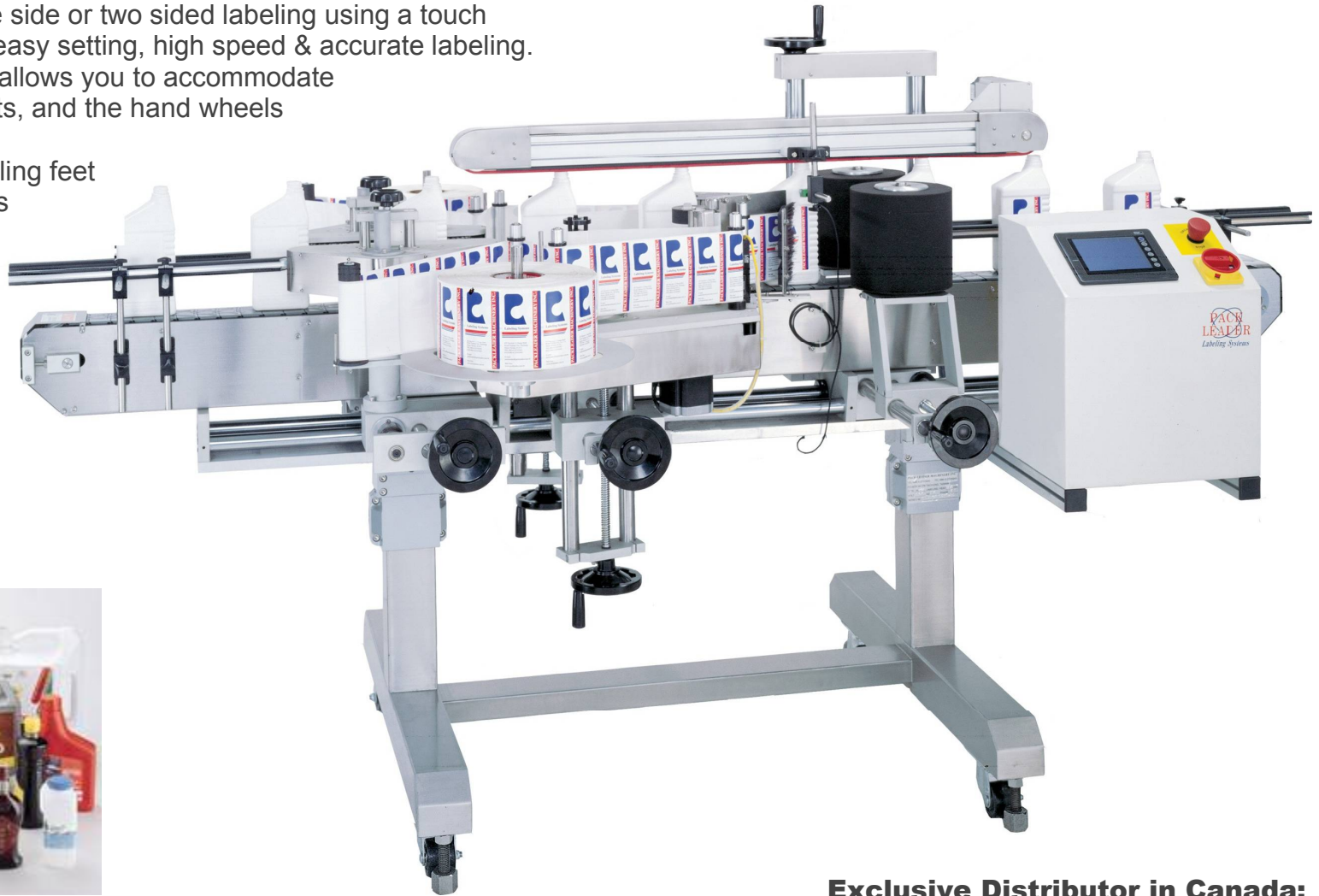

Exclusive Distributor in Canada:
Speedway Packaging Machinery Inc.
www.spmi.ca

PL-622 FRONT & BACK LABELER

Specifications

Voltage	110 VAC 50/60 HZ 1 PHASE
Power	12 amps
Controls	Netcon touch screen
Max. Conveyor Speed	30 m (98') / min.
Max. Dispensing Speed	30 m (98') / min.
Applicator Height	150 mm (5 7/8") / 200 mm (7 7/8")
Conveyor Width	100 mm (4") - Standard 150 mm (6") - Optional
Label Reel Inner Optional	76 mm (3") Allen hot foil coder Allen thermal transfer coder Label bar code validation

Material

Stainless steel and anodized aluminum construction

Dimensions

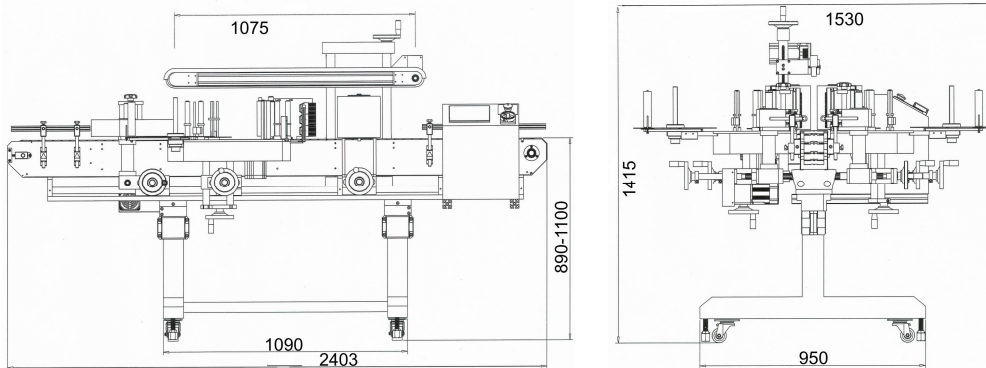

Specifications are subject to change without notice-

Manufactured by:

PACK LEADER MACHINERY INC.

Taiwan, R.O.C.

The PL-622 Front & Back Labeler has powerful features to meet production needs!!!

- ◆ The touch screen control delivers fast, easy set-up.
- ◆ The built in operation manual and instructions makes training efficient.
- ◆ Easy and fast adjustment for reliable label positioning.
- ◆ Can be adapted to different application needs allowing smooth production runs and no hassles for high efficiency.
- ◆ Stepper motor drive for accuracy.
- ◆ Set label position with a touch of a button, no need to adjust the sensor.
- ◆ When the programmable counter reaches a pre-set setting, it will automatically stop for convenient production control.
- ◆ Convenient synchronized speed selections.
- ◆ Integrated missing label detection to prevent mislabeling.
- ◆ Adjustable printer dwell time for clear coding.
- ◆ 30 memory slots to store labeling parameters for future use.
- ◆ For single product conveyor lines, it can automatically start itself and label when power is restored.
- ◆ High mobility—the intricate machine is designed for mobility. It has a square tubular H shape footprint and coupled with casters and threaded leveling feet, provides a wide range of adjustments. The fast labeling speed, aesthetic outline and small footprint contributes to its versatility. Easy to integrate into a production line or in stand alone operation, it is the best machine in terms of cost and performance.

Exclusive Distributor in Canada:

SPEEDWAY PACKAGING MACHINERY INC.

P.O. Box 520

10 Gormley Industrial Ave., Unit 1

Gormley, Ontario

L0H 1G0

905-888-5344